

## Tool post Capto Power-operated tool clamping

Integrated calibration edge

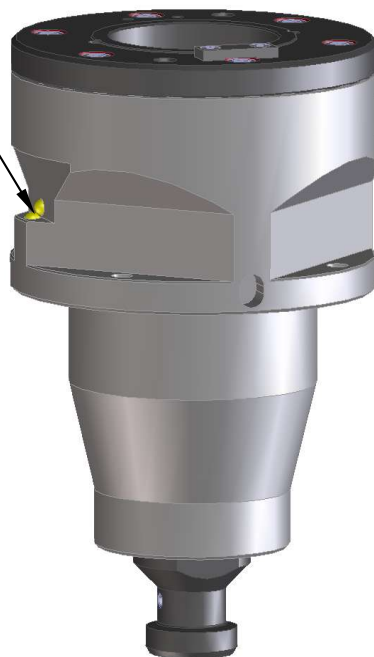

- To fix Capto-tool shanks
- Suitable for tool adjustment
- Integrated calibration edge
- Case-hardened, bronzed and ground

Size Capto	Tool post size I		Tool post size II	
	Item no.	„Z“ <sup>1)</sup>	Item no.	„Z“ <sup>1)</sup>
C3	6001C03	52	6202C03	16
C4	6001C04*	52	6202C04*	16
C5	6001C05*	52	6202C05*	16
C6	6001C06*	52	6202C06*	16
C8 / C8X	6001C08*	52	6202C08*	16
C10	6001C10	102		

\* Suitable for tool identification

- Suitable for »A.C.E.« spindle

- Clamping element (Item no. 03211298) for high precision spindle HGV-UZ size I/II

<sup>1)</sup> Loss in measuring length „Z“

Rev. 2012-04-17/11/fc/ subject to change without notice